

SCD Series



SPECIFICATIONS

Input Voltage 24 VAC $\pm 20\%$, 20 to 36 VDC Class 2
 Analog Output 4-20 mA/0-5 VDC/0-10 VDC
 (selectable)
 Sensor Current Draw 20-36 VDC 40 mA avg.,
 105 mA max.
 24 VAC 50 mA avg., 150 mA max.
 Operating Temperature Range 0° to 50°C
 (32° to 122°F)
 Operating Humidity Range 0-95%
 (noncondensing)
 Housing Material High impact ABS plastic
 Terminal Block Wire Size 0.08 to 2.1 mm²
 (28 to 14 AWG)
 Terminal Block Torque 0.5 to 0.25 N-m
 (1.8 to 2.2 in-lb)

CO₂ Transmitter

Sensor Type Non-dispersive infrared (NDIR),
 diffusion sampling
 Output Range 0-2000 ppm
 Accuracy $\pm 1.5\%$ of measurement range
 $\pm 2\%$ of measured value*
 Repeatability ± 20 ppm $\pm 1\%$ of measured value
 Response Time <60 seconds for 90%
 step change

RH Transmitter

HS Sensor Digitally profiled thin-film capacitive
 (32-bit mathematics); U.S. Patent 5,844,138
 Accuracy $\pm 2\%$ from 10 to 80% RH @ 25°C;
 Hysteresis 1.5% typical
 Linearity Included in Accuracy spec.
 Stability $\pm 1\%$ @ 20°C (68°F) annually, for two years

Schneider Electric's SCD series of duct mount sensors measure the levels of CO₂, RH (if equipped) and temperature of air inside a duct. The CO₂ sensor employs the Automatic Baseline Calibration (ABC) feature which enables the sensor to operate within accuracy specifications for the calibration interval of 5 years. The temperature element is warranted to meet accuracy specifications for a period of 5 years. RH equipped models of the SCD feature a replaceable humidity element that is warranted to meet accuracy specifications for a period of 1 year. HS2NX and HS2XX replaceable humidity elements are available through Schneider Electric. To maintain accurate functionality, keep all vents clear and free of dust, debris, etc.

Output Range 0 to 100% RH
 Temperature Coefficient $\pm 0.1\%$ RH/°C above or
 below 25°C (typical)

Temperature

Sensor Type Thermistor
 Accuracy $\pm 0.5^\circ\text{C}$ ($\pm 1^\circ\text{F}$) typical

Relay Contacts

1 Form C 1 A @ 30 VDC, resistive; 30 W max.

EMC Conformance

EN 6100-6-3: 2007 Class B; EN 61326-1: 2006
 Class B; EN61000-6-2: 2005

* Accuracy is specified at NTP (20°C at 101.3 kPa), with 24 VDC supplied power, and rising humidity.

In the event that validation gas is required, the accuracy of validation gas mixture must be added to the sensor specified accuracy for absolute measurements.

DIMENSIONS

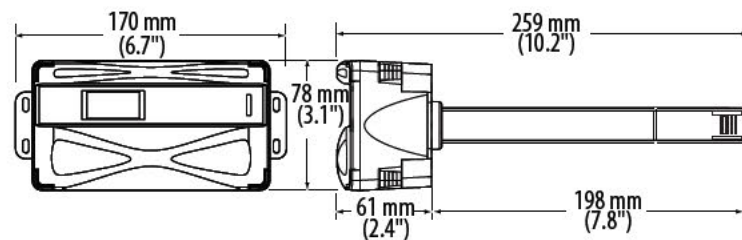

INSTALLATION

1. Choose a location to mount the sensor. The centerline of the housing must be parallel to the direction of air flow in the duct.
2. Use the mounting diagram to drill four holes in the duct for securing the sensor.
3. Insert the probe into the hole. Rotate the housing so that the widest surface is perpendicular to the air flow.
4. Attach the sensor to the duct using sheet metal screws. Make sure that the gasket on the back of the housing is compressed between the housing and the duct for a secure fit.
5. Wire the device. See the Wiring section.
6. Select mA or Volt output using the selector slide switch. See the diagram in the Wiring section for the location of this switch.
7. Use the DIP switches to configure the voltage output range (if Volt is selected in step 6), the relay setpoints, and the deadband. See the DIP Switch Settings section.

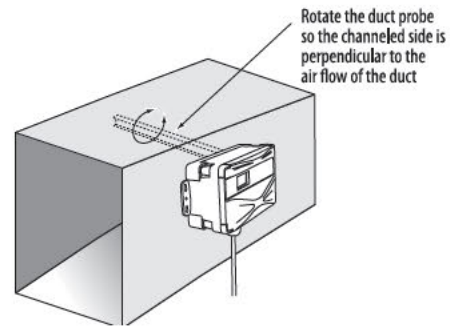
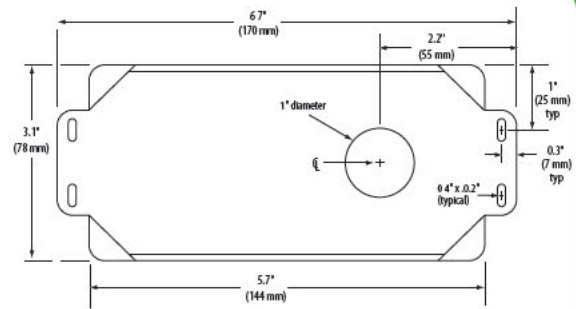

WIRING

1. Feed the control wire through the grommated compression fitting on the bottom of the housing.
2. Remove the terminal blocks by pulling the assemblies away from the main board.
3. Connect wires as shown and push the terminal blocks back into the black receptacles.
4. Tighten the compression fitting around the control wire until it is sealed.
5. Refer to the specifications for power requirements and relay rating.

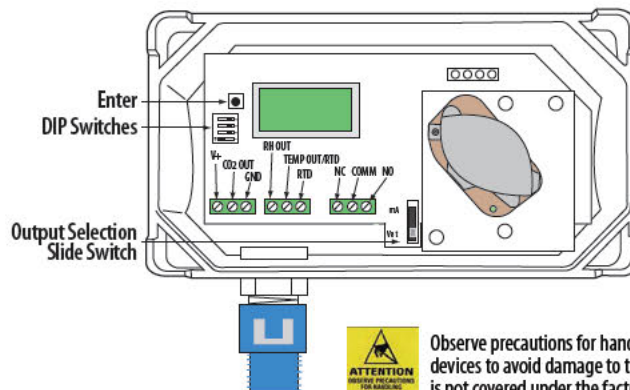

Observe precautions for handling static sensitive devices to avoid damage to the circuitry that is not covered under the factory warranty.

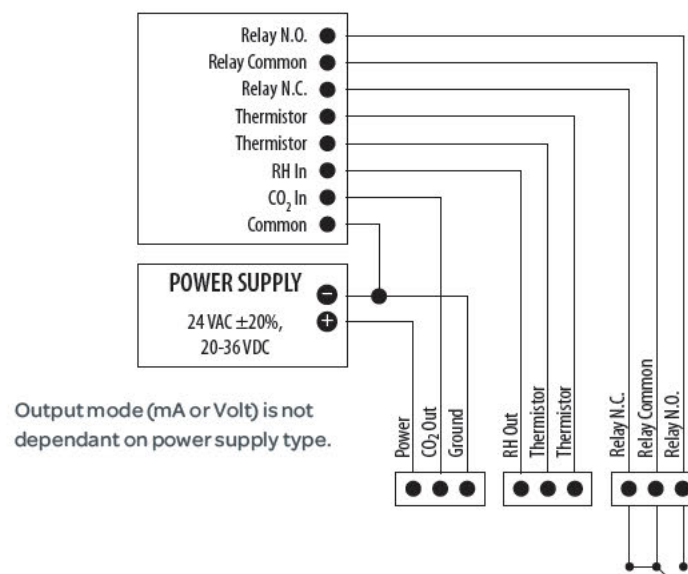

© 2014 Schneider Electric. All rights reserved.

DIP SWITCH SETTINGS

1. If Volt output is selected, select 5 V (0-5 VDC) or 10 V (0-10 VDC) using switch 1 on the four-throw DIP switch.
2. Select a relay setpoint of 800, 1000, or 1200 ppm of CO₂ using switches 2 and 3 (see the setpoint diagram below for DIP switch settings).
3. Select a deadband of 50 ppm or 100 ppm using switch 4. This setting allows for additional flexibility when using the relay setpoint. The actual relay trip point is the setpoint ppm ± the deadband ppm.

Example: The relay setpoint is set for 1000 ppm and the deadband is set for 50 ppm. With dropping CO₂ levels the relay trips at 950 ppm (1000 ppm – 50 ppm), and with rising CO₂ levels the relay trips at 1050 ppm (1000 ppm + 50 ppm).

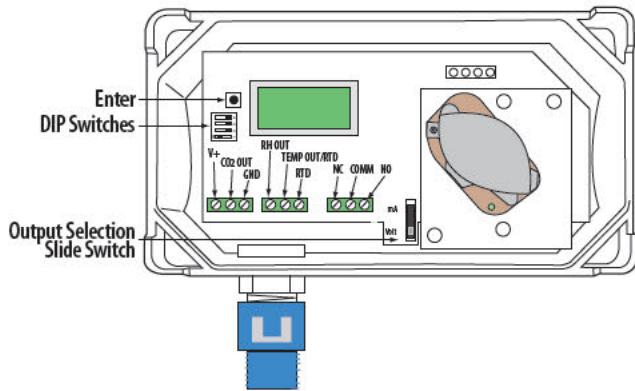

Observe precautions for handling static sensitive devices to avoid damage to the circuitry that is not covered under the factory warranty.

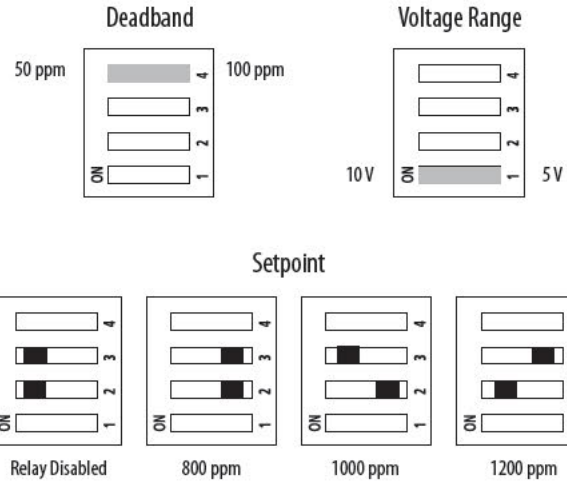

ABC CALIBRATION ALGORITHM

ABC (Automatic Baseline Calibration) is a patented self-calibration feature that automatically adjusts the CO₂ sensor to compensate for drift. When ABC is enabled, the sensor records the lowest reading within every 24-hour interval and compares these values over a running 7-day or 28-day period. If a statistically significant amount of drift is detected, the ABC applies an automatic correction factor. This enables the sensor to operate within specifications for the 5-year calibration interval.

ABC Settings

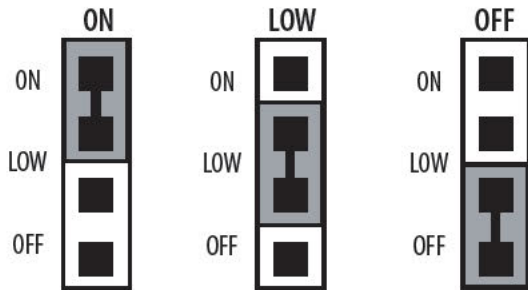

ON POSITION. Recommended Setting. Use the ON setting for applications where the building is unoccupied within a 24-hour timeframe.

LOW POSITION. Use the LOW setting for buildings occupied 24 hours a day.

OFF POSITION. Not Recommended.

NOTE: After changing the ABC settings, power cycle the unit for changes to take effect.

OUTPUT SCALING

Output scaling: 0-2000 ppm

	CO ₂ ppm	0-5 Volt Output	0-10 Volt Output	mA Output
Outside	300-500	0.75 to 1.25	1.5 to 2.5	6.4 to 8
Over-Ventilated	Under 600	under 1.5	Under 3	Under 8.8

CALIBRATION PROCESS

1. Remove the cover and connect the gas cylinder hose to the plastic port located on the sensing module. Note: only connect one sensor to the calibration gas cylinder at a time.
2. Set DIP switches 2 and 3 to the ON position to enable calibration.
3. Start flowing nitrogen gas (0 ppm CO₂). Use a flow rate of 0.3 to 0.5 liter/minute.
4. Push and hold the Enter button until the red LED illuminates.
5. Calibrate until the red LED turns off (approximately 5 min). The unit will return to normal operation when finished. Return the DIP switches to the Setpoint position (see the DIP Switch Settings section) when the calibration is complete.

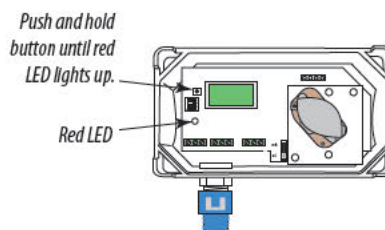
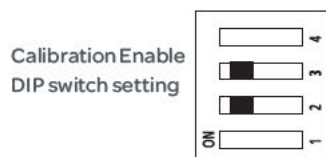
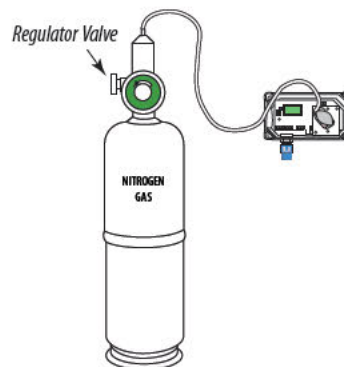
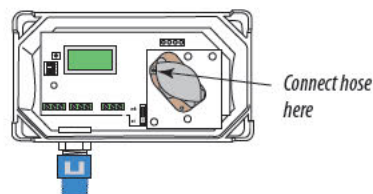

HUMIDITY SENSOR REPLACEMENT

SCD models with optional RH have replaceable humidity sensors.

To Replace Humidity Sensor:

1. Power down unit
2. Remove SCD from duct to access probe tip.
3. Open tip of duct probe
4. Slide old HS sensor off pins
5. Slide new HS sensor onto pins.
6. Re-install SCD in duct and re-secure with screws provided.
7. Power unit back on

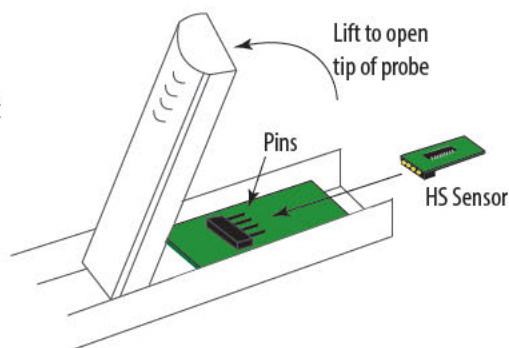

AVAILABLE PRODUCTS

Part Number	Model Number	Duct Mounted CO ₂ Sensor with			
		Temp	2% RH	LCD	System
5152300000	SCD110	x			Vista 1.8K
5152302000	SCD110-D	x		x	Vista 1.8K
5152304000	SCD110-H	x	x		Vista 1.8K
5152306000	SCD110-D-H	x	x	x	Vista 1.8K
5152308000	SCD210	x			I/NET 10K T2
5152310000	SCD210-D	x		x	I/NET 10K T2
5152312000	SCD210-H	x	x		I/NET 10K T2
5152314000	SCD210-D-H	x	x	x	I/NET 10K T2
5152316000	SCD510	x			Continuum 10K T3
5152318000	SCD510-D	x		x	Continuum 10K T3
5152320000	SCD510-H	x	x		Continuum 10K T3
5152322000	SCD510-D-H	x	x	x	Continuum 10K T3
5152324000	SCD610	x			Satchwell 10K T3 Resistor/Shunt
5152326000	SCD610-D	x		x	Satchwell 10K T3 Resistor/Shunt
5152328000	SCD610-H	x	x		Satchwell 10K T3 Resistor/Shunt
5152330000	SCD610-D-H	x	x	x	Satchwell 10K T3 Resistor/Shunt
5152332000	SCD810	x			I/A 10K T3 w/Shunt
5152334000	SCD810-D	x		x	I/A 10K T3 w/Shunt
5152336000	SCD810-H	x	x		I/A 10K T3 w/Shunt
5152338000	SCD810-D-H	x	x	x	I/A 10K T3 w/Shunt
5152339010	HS2NX	Replaceable RH Element, 2%, NIST.			
5152339000	HS2XX	Replaceable RH Element, 2%.			

THERMISTOR TABLE

°C	°F	Vista 1.8K	I/NET 10K T2	Continuum 10K T3	Satchwell 10K T3 w/Resistor & Shunt	I/A 10K T3 w/Shunt
-50	-58	82,207	692,644	447,497	9,781	10,736
-40	-40	42,848	344,702	242,599	9,604	10,523
-30	-22	23,563	180,148	136,484	9,318	10,180
-20	-4	13,585	98,324	79,472	8,884	9,663
-10	14	8,167	55,786	47,772	8,272	8,941
0	32	5,096	32,773	29,575	7,480	8,018
5	41	4,077	25,456	23,504	7,024	7,493
10	50	3,287	19,931	18,809	6,541	6,941
15	59	2,671	15,725	15,146	6,039	6,372
20	68	2,185	12,497	12,271	5,530	5,800
25	77	1,800	10,000	10,000	5,025	5,238
30	86	1,492	8,055	8,195	4,534	4,696
35	95	1,245	6,528	6,752	4,066	4,184
40	104	1,044	5,323	5,592	3,627	3,707
45	113	881	4,365	4,655	3,222	3,271
50	122	747	3,599	3,893	2,854	2,875

© 2014 Schneider Electric. All rights reserved.